

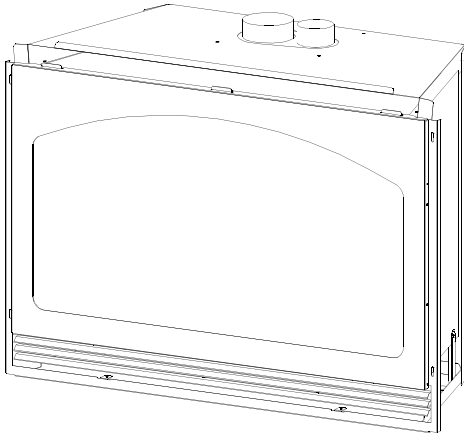

## Model #911-XXL

Direct Vent Gas Fireplace Insert

### INSTALLATION & OPERATING MANUAL



U.S. PATENT #5,931,154  
U.S. PATENT #6,004,493  
U.S. PATENT #6,029,655

**WARNING:** If the information in these instructions are not followed exactly, a fire or explosion may result causing property damage, personal injury or loss of life.

Do not store or use gasoline or other flammable vapors in the vicinity of this or any other appliance.

#### WHAT TO DO IF YOU SMELL GAS:

- ◆ Do not try to light any appliance.
- ◆ Do not touch electrical switches; do not use the phone in your building.
- ◆ Immediately call your gas supplier from a neighbor's phone. Follow the gas supplier's instructions.
- ◆ If you cannot reach your gas supplier, call the fire department.

- Installation and service must be performed by a qualified installer, service agency or the gas supplier.

This appliance may be installed in an aftermarket permanently located, manufactured (mobile) home, where not prohibited by local codes. This appliance is only for use with the type(s) of gas indicated on the rating plate. This appliance is not convertible for use with other gases, unless a certified kit is used.



#### IMPORTANT:

**READ ALL INSTRUCTIONS CAREFULLY BEFORE INSTALLATION.  
FAILURE TO INSTALL THIS FIREPLACE INSERT CORRECTLY CAN  
CAUSE SERIOUS STRUCTURAL AND FIRE HAZARDS AND MAY VOID  
YOUR WARRANTY.**

[www.kozyheat.com](http://www.kozyheat.com)



October 2006

## INDEX

Fireplace Insert Specifications .....	1
Safety Requirements .....	1
Requirements of Existing Fireplace .....	2
Fireplace Insert Components .....	3
Preparing The Existing Fireplace .....	4
Gas Line Installation Requirements - Minimum/Maximum Pressures .....	4-5
Insert Preparation .....	6-7
Remove the Glass Assembly .....	6
Remove the Millivolt Board .....	6
Remove the Air Duct .....	7
Installing the Insert .....	7-13
Restrictor Installation .....	7
Co-Linear Vent System .....	8
Install the Vent System .....	9
Position the Insert & Secure the Air Duct .....	10
Replace the Millivolt Board .....	11
Log Installation .....	12
Assemble & Attach the Shroud .....	13-15
Complete the Fan Installation .....	16
Complete the Installation - Initial Lighting / Seasonal Heat Dump Adjustment / Replace the Glass Assembly / Replace the Lower Grill .....	17
Thermostat - Remote Control - Wall Switch Installation .....	18
Lighting & Shutdown Procedures .....	19-20
Manifold (outgoing) & Inlet (incoming) Pressure Check Procedures .....	21
Maintenance Requirements .....	22
Troubleshooting .....	23-24
Gas Conversion Kit .....	25-26
Replacement Parts .....	27
Warranty Policy .....	28-29

# MODEL JACKSON XXL DIRECT VENT GAS BURNING FIREPLACE INSERT

## INSTALLATION & OPERATING INSTRUCTIONS

### IMPORTANT: READ THIS MANUAL BEFORE INSTALLING AND USING THIS FIREPLACE

This fireplace has been tested to and complies with ANSI Z21.88-2002, CSA 2.33-2002 "VENTED GAS FIREPLACE HEATERS" by OMNI-Test Laboratories, Beaverton, Oregon for U.S. Installations only. Installation must conform with local building codes or in the absence of local building codes, with the National Fuel Gas code, ANSI Z223.1 NFPA 54 - Current Edition.

#### SPECIFICATIONS:

Height (top of firebox): 25 1/4"    Height (top of air duct): 27 1/2"  
Width: 38 1/4"    Back Width: 26 1/4"    Depth: 16 1/8"

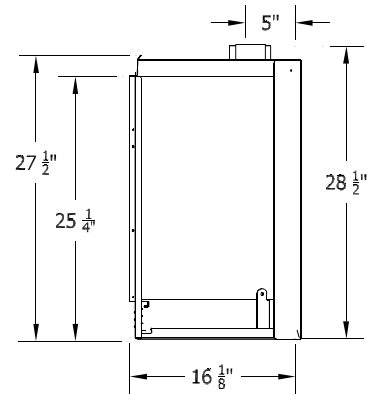
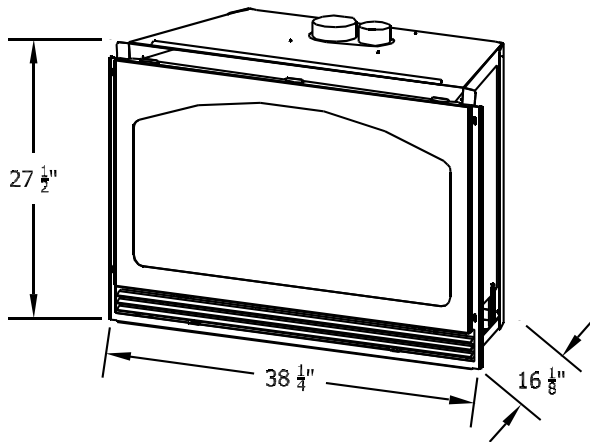

*NOTE: Minimum existing opening width required: 38 1/2"*

Do not use this fireplace if any part has been under water. Immediately call a qualified service technician to inspect this appliance and to replace any part of the control system and any gas control which has been under water.

WARNING: DO NOT REPLACE THIS BURNER WITH ANY OTHER SIZED BURNER. REPLACEMENT WITH AN UNAUTHORIZED BURNER CAN RESULT IN TEMPERATURES EXCEEDING THE LIMITS FOR THIS FIREPLACE AND VOID YOUR WARRANTY.

DUE TO HIGH TEMPERATURES, THIS FIREPLACE SHOULD BE LOCATED OUT OF TRAFFIC AND AWAY FROM FURNITURE AND DRAPERIES

The efficiency rating of this appliance is a product thermal efficiency rating determined under continuous operating conditions and was determined independently of any installed system.

YOUNG CHILDREN SHOULD BE CAREFULLY SUPERVISED WHEN THEY ARE IN THE SAME ROOM AS THIS FIREPLACE.

CHILDREN AND ADULTS SHOULD BE ALERTED TO THE HAZARDS OF HIGH SURFACE TEMPERATURE AND SHOULD STAY AWAY TO AVOID BURNS OR CLOTHING IGNITION.

CLOTHING OR OTHER FLAMMABLE MATERIAL SHOULD NOT BE PLACED ON OR NEAR THE APPLIANCE.

#### COMMONWEALTH OF MASSACHUSETTS INSTALLATIONS

WARNING: This Product Must Be Installed By A Licensed Plumber Or Gas Fitter When Installed Within The Commonwealth of Massachusetts.

IMPORTANT: Installation of a CO detector is required in the fireplace room.

CAUTION: THIS FIREPLACE INSERT IS APPROVED FOR INSTALLATION IN MASONRY AND FACTORY-BUILT SOLID FUEL BURNING FIREPLACES.

CAUTION: THIS APPLIANCE MUST NOT BE CONNECTED TO A CHIMNEY FLUE SERVING A SEPARATE SOLID-FUEL BURNING APPLIANCE.

**THE EXISTING FIREPLACE MUST MEET THE FOLLOWING REQUIREMENTS:**

1. The existing fireplace & chimney must be clean and in good working order and constructed of non-combustible materials.
2. A gas line must be able to be installed to the insert.
3. Any chimney cleanouts must fit properly.
4. Existing Chimney: - Class 'A' metal chimney: Co-linear 3" x 4" venting - 8" minimum inside diameter.  
- Masonry Chimney: Co-linear 3" x 4" venting - 6" x 8" minimum inside diameter.

Chimney height: Height of existing chimney must be at least: 11 ft.  
Maximum height of existing chimney: 40 ft.

To Determine the length of your existing chimney:

A) Remove the chimney cap.

NOTE: It is helpful to have two people complete the next step in determining chimney height.

B) With one person at the fireplace and the other person at the top of the chimney, measure from the base of the fireplace to the top of the chimney. Subtract 24" for the height of the insert. This is the total length of co-linear flexible aluminum you will require.

MEASUREMENT FROM BASE OF FIREPLACE TO TOP OF CHIMNEY: \_\_\_\_\_  
LESS: -24"  
TOTAL CHIMNEY LENGTH REQ.: \_\_\_\_\_

5. The minimum inside dimensions of the existing fireplace must be:  
Height: 28"                      Front Width: 38 1/2"  
Depth: 16 1/2"                      Width at minimum depth location: 26 3/4"

NOTE: The refractory / firebrick may be removed to achieve minimum opening size requirements.

6. Minimum clearance from door frame to side wall: 4 1/2"  
Minimum clearance from door frame to a combustible mantel: 16"      Mantel depth: 10"

**MINIMUM OPENING DIMENSIONS**

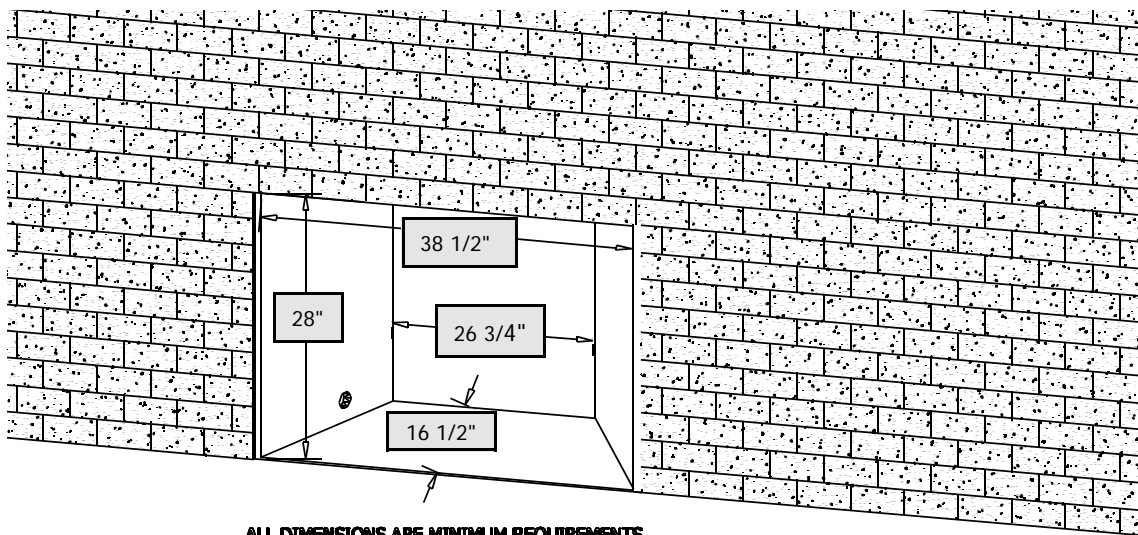

**ALL DIMENSIONS ARE MINIMUM REQUIREMENTS**

## FIREPLACE COMPONENTS:

Check the assembly diagram below to ensure you have all the necessary components to properly install this fireplace insert.

This insert includes the following:

1. Fireplace Insert.
2. Spring-loaded latch glass assembly.
3. Millivolt board with burner cover.
4. 150 CFM fan with limit switch and speed control.
5. Co-linear air duct.
6. Log set (See page #14).

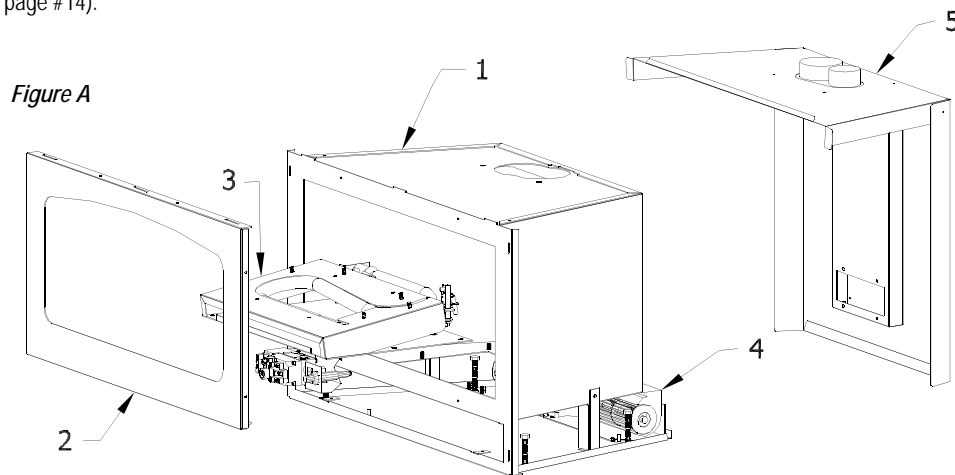

**WARNING:** Failure to position the parts in accordance with these diagrams or failure to use only parts specifically approved for this appliance may result in property damage or personal injury.

**Additional components which are necessary for proper installation are:**

### 1. Vent System:

**Part #815-CL:** For use with minimum 6" x 8" I.D. masonry or 8" I.D. Class 'A' metal chimneys - Includes 12 ft. compressed, expandable to 25 ft. co-linear 3" x 4" flexible chimney, and termination cap. If your existing chimney is higher than 25 ft. above the fireplace, an extension kit (Part #510) must be used to properly extend the 3" intake and 4" exhaust up to a maximum of 40 ft.

**2. Shroud - 3 pc & 4 pc.:** A standard shroud, 48" wide x 32" high is available for this insert and will fit most applications. Custom shrouds may be ordered on a non-returnable basis. When ordering a custom shroud, please specify the existing fireplace front opening height and width.

**3. Blank Shrouds - 3 & 4 pc.** blank shrouds are available for on-site custom fit applications and are sized to the opening after the insert has been installed. The interior perimeter is properly sized to fit onto the insert. The outer perimeter must be cut, formed and finished (painted).

**4. Upper & Lower Grill set** - Several grill set options are available. Contact your dealer for more information.

## A) PREPARE THE EXISTING FIREPLACE

**WARNING:** CUTTING ANY SHEET-METAL PARTS OF THE FIREPLACE, IN WHICH THIS GAS FIREPLACE INSERT IS TO BE INSTALLED, IS PROHIBITED.

- 1) The refractory, glass doors, screen rails, screen mesh and log grates may be removed from the fireplace before installing this gas fireplace insert.
- 2) Any smoke shelves, shields and baffles may be removed if attached by mechanical fasteners.
- 3) If necessary, remove the firebrick on the sides and back of the existing fireplace to obtain at least the minimum opening requirements listed on page #2.
- 4) The fireplace flue damper can be fully blocked open or removed for installation of this gas fireplace insert.
- 5) Trim panels or surrounds shall not seal ventilation openings in the fireplace.
- 6) Remove the existing chimney cap from the chimney.
- 7) Clean the chimney and inside of the fireplace to prevent creosote smell from entering the home.
- 8) Place '**THIS UNIT HAS BEEN MODIFIED**' label in the bottom of the firebox so it will be visible if this gas fireplace insert is removed.

## B. RUN THE GAS LINE

**CAUTION:** Installation of the gas line must only be done by a qualified person in accordance with local building codes.

This fireplace insert is equipped with a 3/8" flexible gas line connection 18" long.

**CAUTION:** The manual shut off valve and millivolt board flexible gas line must not extend outside the insert cavity. See the WARNING label affixed to the flexible gas line for additional installation instructions and warnings.

1. Run the gas line into the fireplace, preferably through the side or back, 2" from the bottom of the fireplace. See Figure B-1 on page #5.

If installing this gas fireplace insert into a factory-built fireplace and the factory-built fireplace has no access holes(s) provided, an access hole of 1 1/2" or less may be drilled through the lower sides or bottom of the firebox in a proper workmanship like manner. This access hole must be plugged with non-combustible insulation after the gas supply line has been installed.

A flexible connector should then be attached to the previously run gas line to the point where the manual shut off valve and millivolt board flexible gas line will connect.

**IMPORTANT:** An accessible shut off valve (included with this fireplace insert) must be installed up stream from the regulator.

**IMPORTANT: DO NOT RUN THE GAS LINE IN A MANNER THAT WOULD OBSTRUCT THE OPERATION OF THE FAN OR POSITION OF THE SPEED CONTROL.**

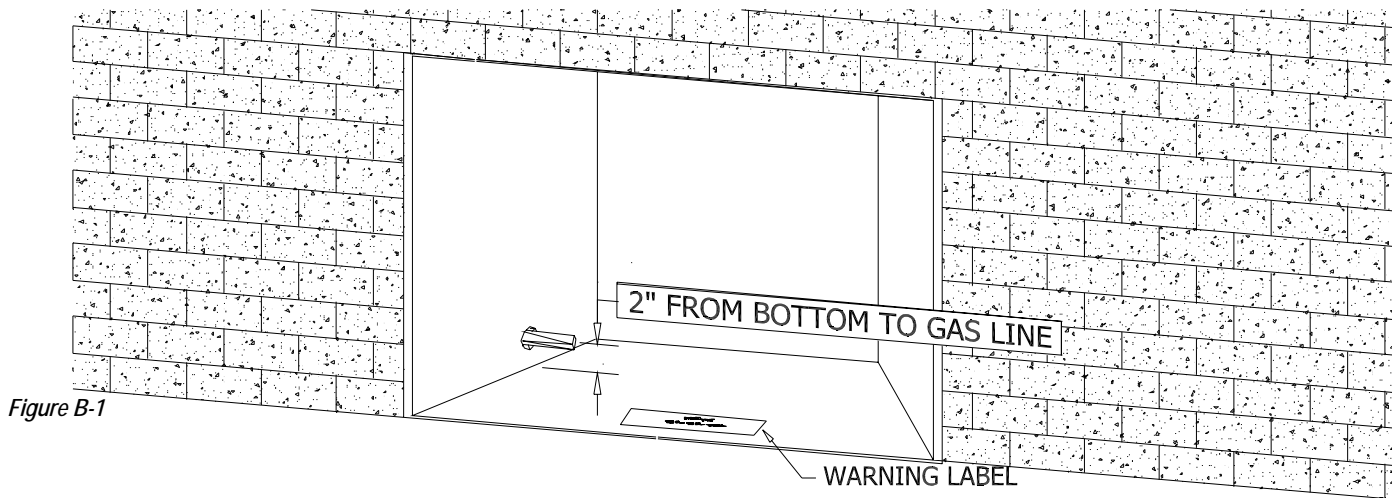

Figure B-1

2. This fireplace insert is designed to accept either a 3/8" or 1/2" gas line approved for gas appliances. Consult local building codes to properly size the gas supply line leading to a 3/8" reduction.
3. Connect the manual shut off valve to the previous run gas line.
4. The gas line will be connected to the millivolt board later in this manual.

**IMPORTANT:**  
**ALL CONNECTIONS WHETHER FIELD OR FACTORY MADE MUST BE CHECKED FOR LEAKS.**

**NOTE:** This appliance and its individual shut off valve must be disconnected from the gas supply piping system during any pressure testing of that system at test pressures in excess of 1/2 psi.

**NOTE:** This appliance must be isolated from the gas supply piping system by closing its individual manual shut off valve during any pressure testing of the gas supply piping systems at test pressures equal to or less than 1/2 psi.

**Pressure check taps for both the manifold (outgoing) and inlet (incoming) pressures are located in front of the gas valve. The right pressure tap is the manifold pressure and the left pressure tap is the incoming pressure. Follow instructions on page #21 for checking these pressures.**

**NATURAL GAS:**

The minimum inlet gas supply pressure: 5.0 in. W.C.  
 Recommended inlet gas supply pressure: 7.0 in. W.C.  
 The maximum inlet gas supply pressure: 10.5 in. W.C.  
 Manifold Pressure: 3.5 in. W.C.  
 Manifold Pressure (lo setting): 1.7 in. W.C.  
 Orifice size (0-2000 ft): 30     Input rating: 42,000 BTU/Hr.  
 Minimum Input rating: 29,500 BTU/Hr.

**LP GAS:**

The minimum inlet gas supply pressure: 11.0 in. W.C.  
 Recommended inlet gas supply pressure: 11.0 in. W.C.  
 The maximum inlet gas supply pressure: 13.0 in. W.C.  
 Manifold Pressure: 10.0 in. W.C.  
 Manifold Pressure (lo setting): 6.5 in. W.C.  
 Orifice size (0-2000 ft): 47     Input rating: 42,000 BTU/Hr.  
 Minimum Input rating: 30,000 BTU/Hr.

*For high altitude installations, consult the local gas distributor or the authority having jurisdiction for proper rating methods.*

## C. REMOVE THE FOLLOWING ITEMS FROM THE FIREPLACE INSERT:

### 1. GLASS ASSEMBLY:

- A) Locate the spring-loaded latches securing the glass assembly (under the firebox).
- B) While holding onto the glass frame, pull the latch handles out to release from the clips on the glass assembly.
- C) Pull the bottom of the glass assembly out releasing the tabs at the back of the glass assembly from the slots in the firebox face, then lift up off the tabs at the top of the firebox.
- D) Set aside where it will not be broken.
- E) Remove the log package and bottom refractory from inside the firebox and set aside for installation later in this manual.

Figure C-1

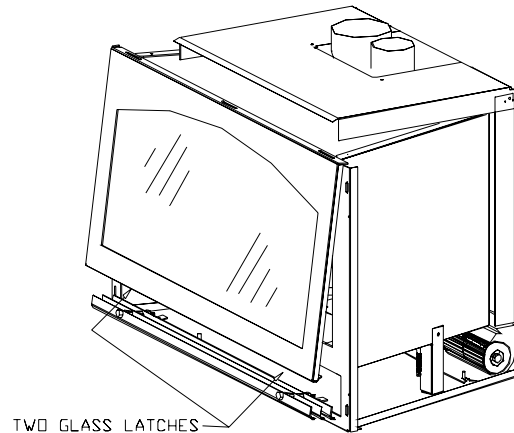

### 2. MILLIVOLT BOARD.

- A) Loosen and remove the (2) nuts securing the burner cover. Remove the burner cover by lifting the front of the cover up, then carefully slide the burner tube off the orifice. Remove entire assembly from the firebox. Figure C-2.
- B) Remove the pilot shield. Figure C-3.

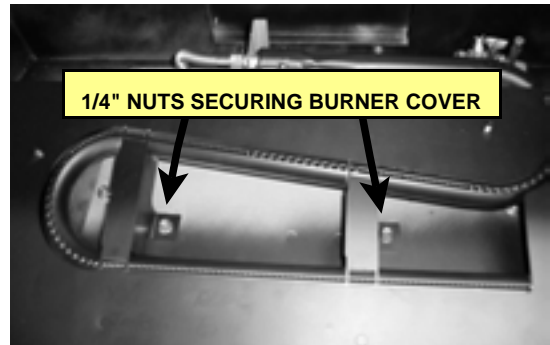

Figure C-2

- C) Loosen and remove the (2) 1/4" nuts securing the millivolt board to the firebox bottom. Lift the board off the studs and remove from the firebox. Figure C-3.

**IMPORTANT: BE CAREFUL NOT TO DAMAGE THE GASKET UNDER THE BOARD.**

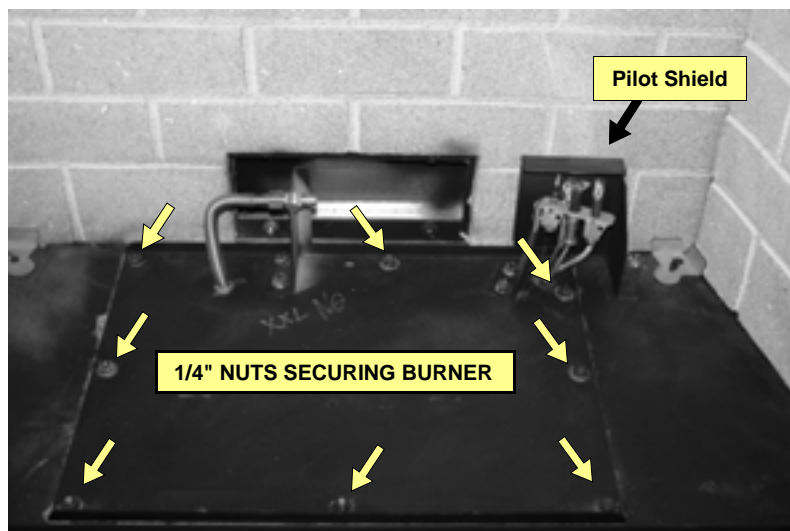

Figure C-3

**NOTE:** The millivolt board is secured with (2) nuts at the factory. After the millivolt board is properly installed it must be secured with 8 nuts as shown above (6 additional nuts are included in the components packet). The burner / cover assembly is then placed over the millivolt board and secured with 2 nuts.

### 3. REMOVE THE AIR DUCT. Figure C-4.

- A. Pull the lower end of the air duct out of the (4) mounting holes at the back and lift the air duct (manifold) up from the top of the firebox and set aside.

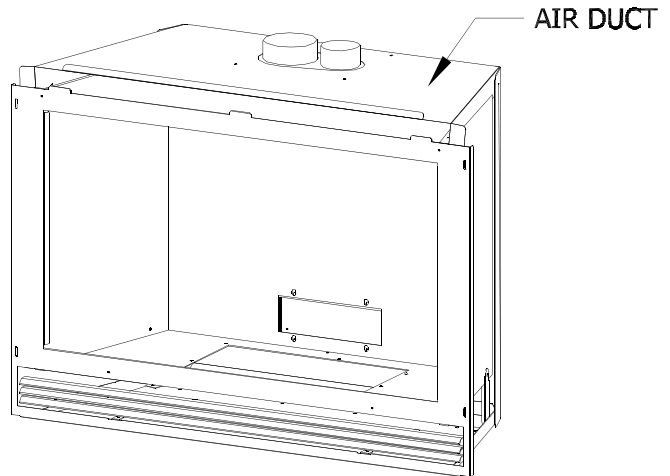

Figure C-4

### D. INSTALLING THE INSERT

**IMPORTANT: ALL STEPS IN SECTION 'A) PREPARE THE EXISTING FIREPLACE' MUST BE COMPLETED BEFORE CONTINUING WITH THIS INSTALLATION.**

#### 1. Restrictor Installation

The restrictor plate included in this fireplace components packet can be installed as either a large or small restrictor, depending on your specific venting configuration.

There are several factors which can affect proper draft of the vent system and the burner operation of a fireplace. Installing a restrictor may be necessary to resolve the problem, even though it may not be required under 'normal conditions'.

Figure D-1  
Large Restrictor

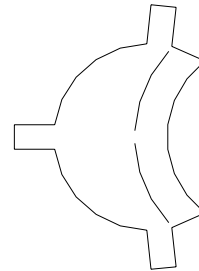
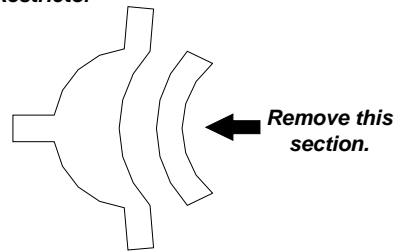

Figure D-2  
Small Restrictor



**IMPORTANT: DO NOT INSTALL IF THE VENTING CONFIGURATION IS AT THE MINIMUM REQUIREMENTS!**

The restrictor included is sized as the 'large' restrictor, Figure D-1. To reduce the size to the 'small' restrictor, simply bend the section without the tabs off at the perforation and discard. Figure D-2.

To install the restrictor, refer to Figure D-3 and bend the tabs 'up' far enough (approximately 180-degrees) so that when positioned into the exhaust pipe, will create tension to hold itself in place. Do not over bend the tabs! Slide the restrictor into the exhaust pipe with the tabs pointing *toward you*. Access to the exhaust pipe can be gained by removing the nuts securing the exhaust baffle at the back of the firebox.

Figure D-3

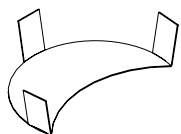

Install with the tabs pointing TOWARD you.

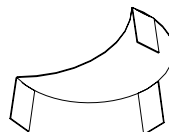

## 2. INSTALL THE VENT SYSTEM

**NOTE:** The 4" exhaust pipe and 3" combustion air intake pipe will extend 25 ft. An optional extension kit (Part #510) is available to extend the #815-CL kit up to a maximum of 40 ft.

- A. Carefully extend the 3" combustion intake and 4" exhaust pipes and extension kit (if used) to equal the total chimney length required.
- B. 1. Slide the 3" intake pipe (end without the collar) onto the collar on the termination cap and secure with 3 self-tapping screws (provided).
2. Place a bead of sealant around the inner edge of the 4" exhaust pipe (end without the collar) and slide onto the corresponding collar on the termination cap. Secure with 3 self-tapping screws (provided). Apply additional sealant around the joint to ensure a seal.
- C. If an extension kit is being used, it must be connected as follows:

**Exhaust extension:** Apply a liberal bead of sealant (provided) around the exhaust adaptor (male) extension pipe and slide into the female connector on the end of the 4" exhaust pipe already attached to the chimney termination plates. Secure with 3 self-tapping screws, (provided). To ensure an air-tight seal, additional sealant should be applied at the point of connection.

**Combustion intake extension:** Apply a liberal bead of sealant (provided) around the male end of the extension kit and slide into female end of the 3" combustion intake pipe attached to the chimney termination plates. Secure with 3 self-tapping screws (provided). To ensure an air-tight seal, additional sealant should be applied at the point of connection.

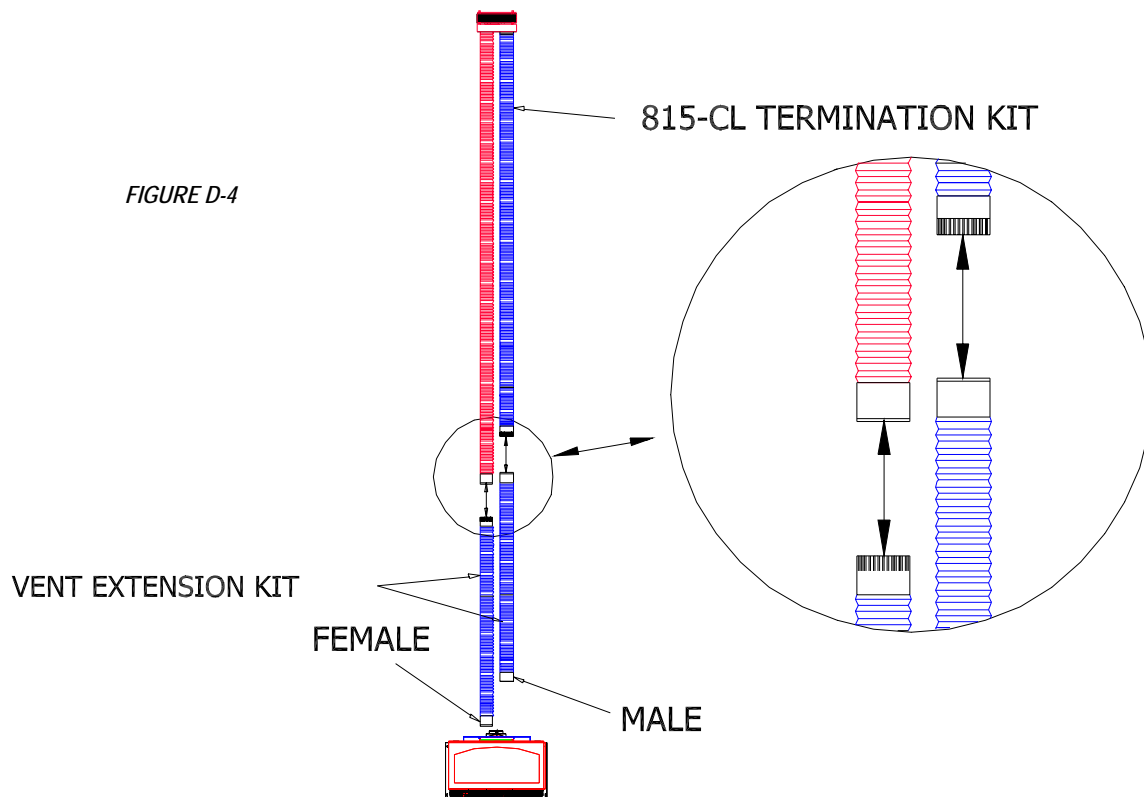

### 3. RUN THE VENT SYSTEM THROUGH THE EXISTING CHIMNEY

❖ **OPTIONAL:** We recommend wrapping the first 3 ft. of the vent system below the termination cap with non-faced fiberglass insulation (secure with wire) before running it through the existing chimney. This will prevent cold air from coming down the existing chimney.

**NOTE:** If there are offsets in the existing chimney, it may be easier to place a weighted rope around the end of the 4" pipe and another weighted rope around the 3" pipe to guide them through it.

**DO NOT ATTEMPT TO TIE ONE ROPE AROUND BOTH PIPES.**

**A.** Guide the rope, if used, and flexible pipes down the existing chimney.

**B.** To secure the chimney termination cap to the existing chimney, apply a liberal bead of sealant (provided) around the top of the existing chimney. Set the termination cap into position.

**OPTIONAL:** Secure the termination cap to the existing chimney with the 2" self-tapping screws and anchor straps provided. Screw holes are located at the sides of the termination cap.

**C.** From inside the opening, grasp the ropes and **CAREFULLY** pull the ropes until the 3" combustion air intake and 4" exhaust pipe is down into the existing fireplace.

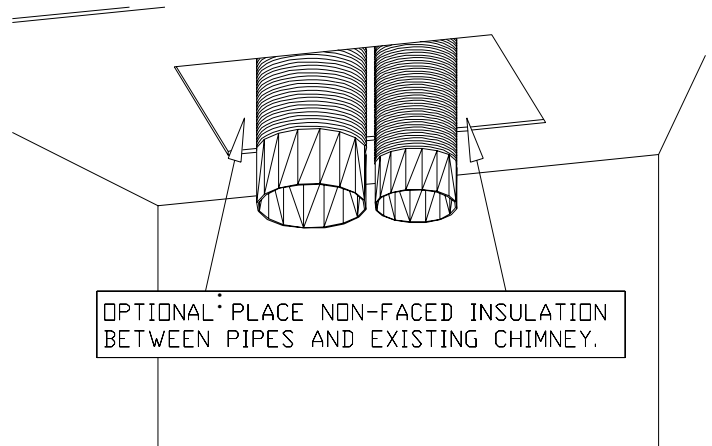

Figure D-5

❖ **OPTIONAL:** We recommend placing non-faced fiberglass batting insulation between the pipes and existing chimney to prevent heat loss up the chimney. (SEE FIGURE D-5)

### 4. CONNECT THE VENT SYSTEM TO THE AIR DUCT

**A.** Place the air duct into the existing fireplace opening.

**B.** Place a bead of sealant (provided) around the 4" exhaust pipe and slide it inside the 4" collar on the duct. Secure with (3) 1/2" self-tapping screws, provided. Apply additional sealant around the joint to ensure an air tight seal.

**C.** Apply a liberal bead of sealant (provided) around the 3" collar on the air duct. Slide the 3" combustion intake pipe over the collar and secure with (3) 1/2" self-tapping screws, provided. To ensure an air-tight seal, apply additional sealant around the joint.

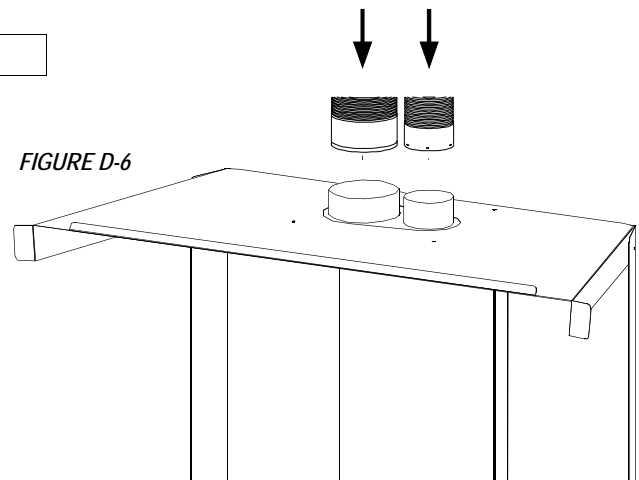

## E. POSITION THE FIREPLACE INSERT:

1. Slide the insert in the fireplace opening.
2. If necessary, level the insert by threading the leveling bolts (included in the components packet) into the nuts mounted in the bottom of the insert behind the lower grill. See Figure E-1.

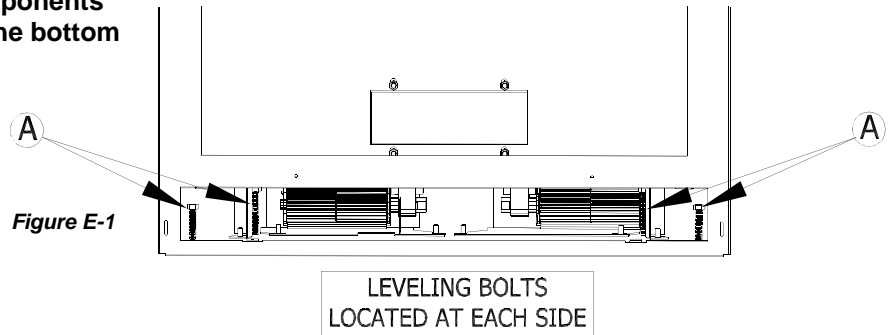

3. Place the air duct onto the fireplace by aligning the studs located on each side of the 4" exhaust duct on the air duct to the two holes in the fireplace top and aligning the (4) mounting studs at the lower end of the air duct, (around the combustion air intake), into the (4) mounting holes at the lower end of the firebox back. Set into position.

NOTE: THE AIR DUCT BACK AND SIDES SHOULD BE ON THE 'OUTSIDE' OF THE FLANGES AT THE BOTTOM, OTHERWISE A RATTLING NOISE MAY OCCUR DURING FAN OPERATION.

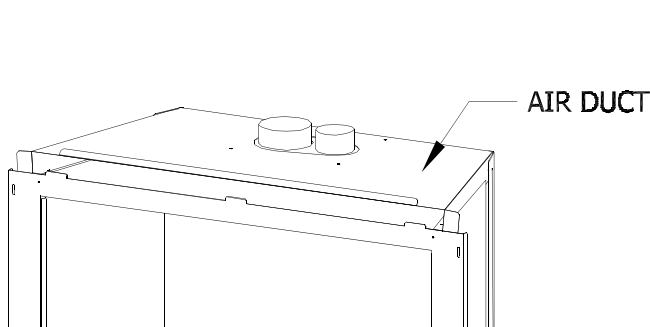
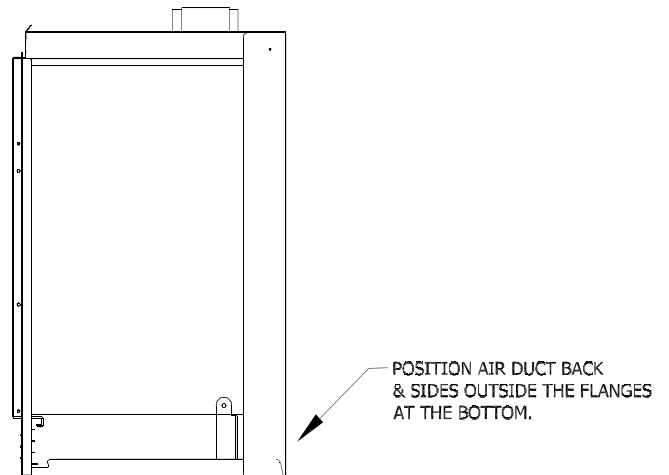

Figure E-2



4. Locate the baffle with seasonal heat dump inside firebox and note the (2) access holes on each side of the heat dump. Secure the air duct to the fireplace with (2) 1/4" nuts through the access holes (A). **IMPORTANT:** Make sure the gasket is properly seated in place.

5. Secure the lower end of the air duct to the firebox by placing a 1/4" nut onto each mounting stud (B) around the intake duct and tighten (4 total). **IMPORTANT:** Make sure the gasket is properly seated in place.

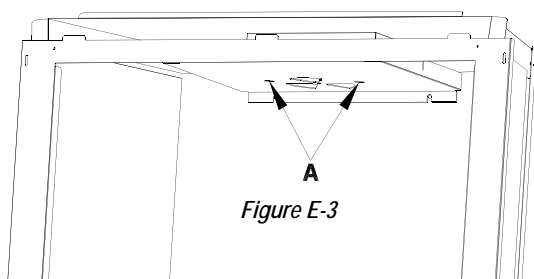
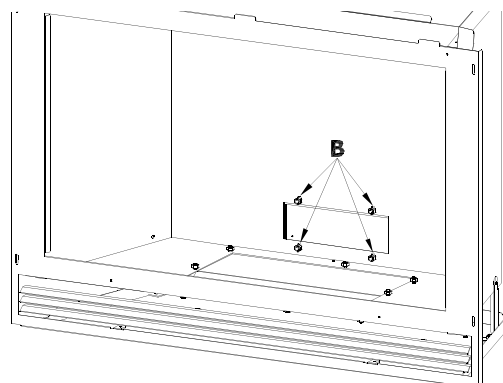

Figure E-3

Figure E-4



## F. REINSTALL MILLIVOLT BOARD INSTALLATION. See Figures F-1 & F-2.

**NOTE:** The millivolt board must be fitted with a gasket, (included) to seal the board. Make certain this gasket is properly placed around the opening before installing the millivolt board.

1. Grasp the millivolt board with both hands and place into the fireplace, lining up the (8) mounting holes in the board to the mounting studs on the bottom of the firebox. **IMPORTANT: BE CAREFUL NOT TO DAMAGE THE GASKET UNDER THE BOARD.**

**CAUTION:** BEFORE SECURING THE BOARD INTO PLACE, MAKE CERTAIN THAT ALL OF THE WIRES (ATTACHED UNDER THE BOARD) ARE CLEAR AND UNOBSTRUCTED.

WHEN INSTALLATION OF THE MILLIVOLT BOARD IS COMPLETE, CHECK TO ENSURE THAT THERE ARE NO WIRES, FLEX LINES, ETC., TOUCHING THE FAN TERMINALS.

2. Attach the (8) nuts (you will use the 2 nuts previously removed & the 6 additional nuts included in the fireplace components packet) and tighten, securing the board in place. Figure F-1.
3. Position the pilot shield behind the pilot assembly. Figure F-1.

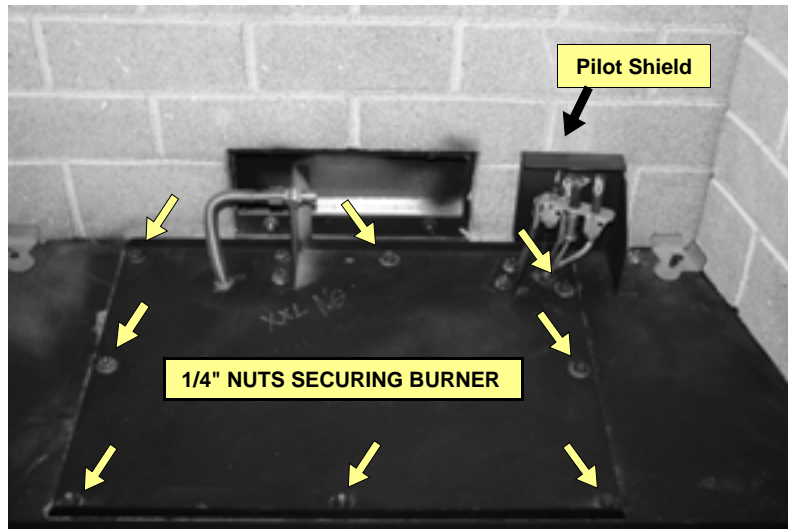

Figure F-1

4. Place the burner cover assembly onto the board, properly seating the burner tube over the orifice and aligning the holes in the mounting brackets attached to the cover to the mounting studs on the millivolt board. Secure with the (2) nuts previously removed. Figure F-2.
5. Connect the flexible gas line to the manual shut off valve.
6. Connect any remote control, wall switch or thermostat wires, if used.

**IMPORTANT:** CHECK ALL CONNECTIONS, WHETHER FIELD OR FACTORY MADE, FOR LEAKS.

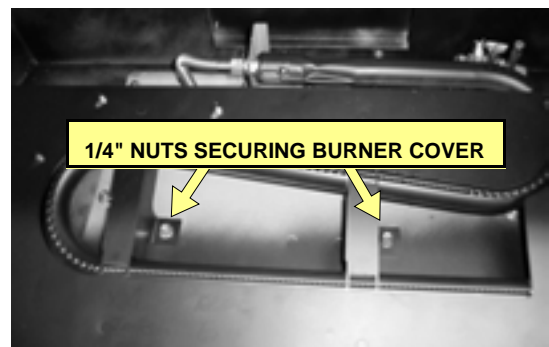

Figure F-2

**G. LOG INSTALLATION. See Figures G-1 - G-3.**

This log set includes: (1) 'S421' log (1) 'BC' log (1) 'BB' log (1) XXL901 BOTTOM REFRACTORY PANELS  
(1) 'S423' log (1) 'S424' log (1) 'AP1' log (1) Embers pkg.  
(1) 'BL' log (1) 'X5' log

1. Position the left & right bottom refractory panels onto front of the burner cover and as shown in Figure G-1.
2. Place the 'S421' log into position aligning the notches in the bottom of the log to the mounting brackets in the cover.
3. Place remaining base logs 'BB', & 'BC' into position on the burner cover aligning the holes in the bottom of the logs to the mounting studs as shown in Figure G-1.

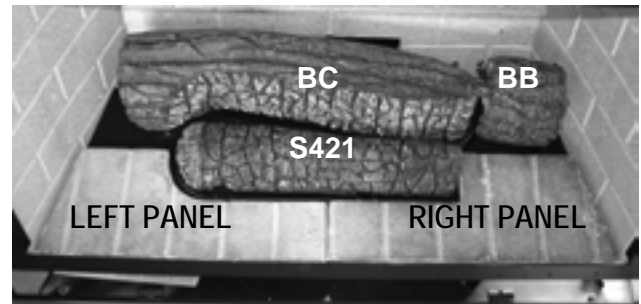

Figure G-1

4. Place the 'S423' & 'S424' logs over the bottom refractory panels, aligning the offset ends at the center. Figure G-2.
5. Place rock wool ember material as desired onto the logs and burner for additional glow.



Figure G-2

**NOTE: You will not use all the embers included in the packet at this time. Save for future use.**

6. Position the 'BL' and 'AP1' logs over the base logs, as shown in Figure G-3.
7. Position the remaining top log 'X5' in place as shown in Figure G-3.

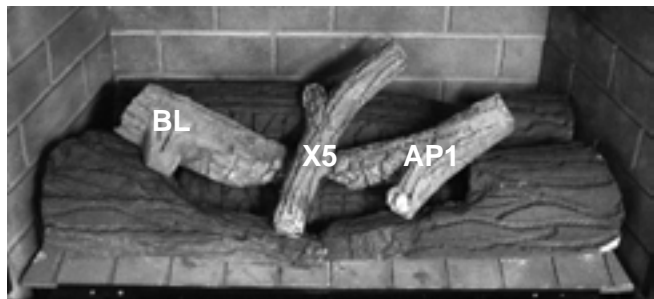

Figure G-3

**ATTENTION HOMEOWNER / INSTALLER:  
TO ACHIEVE OPTIMUM GLOW AND FLAME  
APPEARANCE, IT MAY BE NECESSARY TO  
SLIGHTLY ADJUST THE VENTURI SHUTTER  
POSITION AND/OR LOG POSITIONS.**

**WARNING: FAILURE TO POSITION THE PARTS IN  
ACCORDANCE WITH THESE DIAGRAMS OR  
FAILURE TO USE ONLY PARTS SPECIFICALLY  
APPROVED WITH THIS APPLIANCE MAY RESULT  
IN PROPERTY DAMAGE OR PERSONAL INJURY.**

## H. ATTACH THE SHROUD

**Shroud assembly includes:** (1) Shroud top (1) Set (1 left & 1 right) 'inside fit' brackets  
(1) Shroud left side (12) Phillips head screws  
(1) Shroud right side with on/off rocker switch mounting hole

**Additional items needed:** Rocker switch & wires from the fireplace components packet.  
Upper grill (grill set sold separately).

### ASSEMBLE THE SHROUD - Figures H-1 & H-2

1. Loosen and remove the nuts on the upper grill. Place the upper grill rods through the holes in the shroud top piece and secure with the nuts (A).

NOTE: The louvers on the upper grill should be in the downward position. See Figures H-1 & H-2.

2. Secure the right and left shroud pieces to the top piece by aligning the (2) holes in the side pieces to the holes in the top piece. Secure with the screws (B) provided (2 ea. side). NOTE: Screws are secured from the bottom.

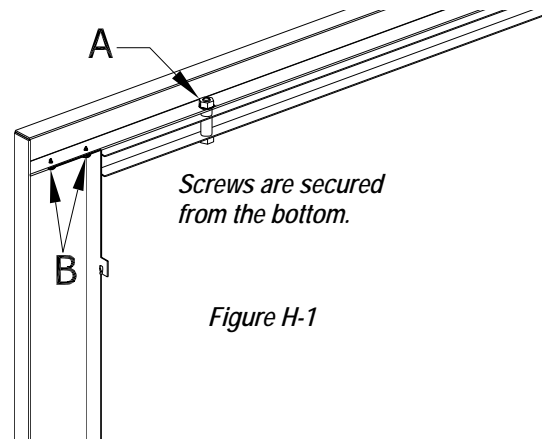

3. Snap the rocker switch in place on the shroud.
4. Slide one connector on one end of each rocker switch wire to the rocker switch.

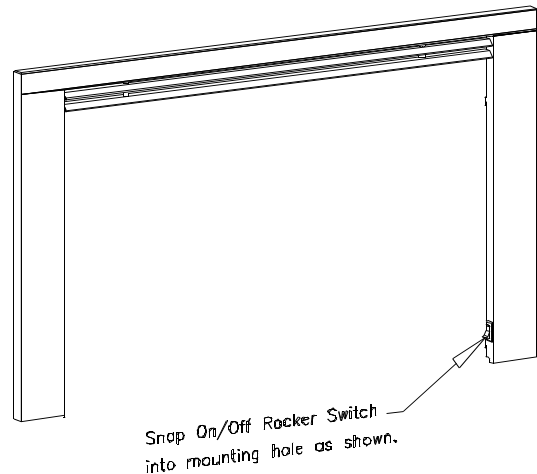

## ATTACH THE SHROUD

### OUTSIDE FIT APPLICATIONS:

1. Attach the shroud to the insert by placing the tabs on the left and right shroud pieces into the holes in the insert. The shroud will set into place. Figure H-3.

Figure H-3

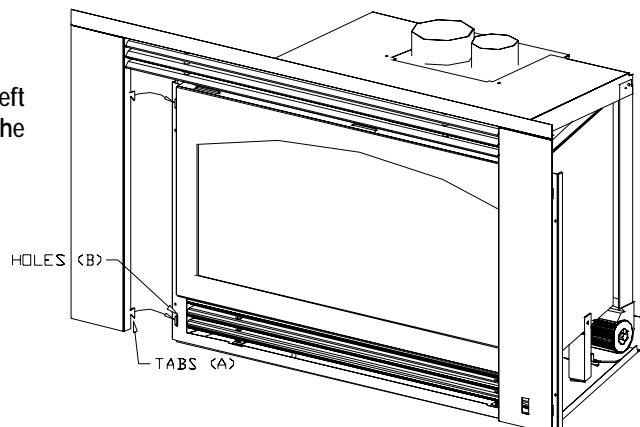

## CONNECT THE ROCKER SWITCH WIRES TO THE VALVE

Refer to Figure N-1 page #24.

1. Slide the remaining connectors on the rocker switch wires to the top and bottom terminals marked 'TH' on the valve.

**IMPORTANT: CHECK ALL CONNECTIONS, WHETHER FIELD OR FACTORY MADE, FOR LEAKS.**

### INSIDE FIT APPLICATIONS:

NOTE: INSIDE FIT APPLICATIONS REQUIRE THE 'INSIDE FIT MOUNTING BRACKETS', INCLUDED WITH THIS KIT, FOR INSTALLATION.

1. Remove the glass assembly. Refer to the fireplace installation manual if necessary.
2. Assemble the shroud, install the upper grill & on/off rocker switch as described on page #12 of these instructions.
3. Referring to Figure H-4, use a tin snips to cut off the lower end of all (4) mounting tabs on the shroud side pieces.

*Cut lower end of each tab at the location shown.*

Figure H-4

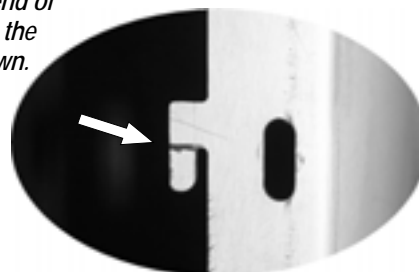

### IMPORTANT- MOUNTING BRACKET ORIENTATION:

The bracket with the notched out section at the bottom is the right mounting bracket. Figure H-5.

The flanges on both mounting brackets shroud should be toward the side of the fireplace. Figure H-5.



Figure H-5 - Note flange orientation

4. Align the holes in the right mounting bracket to the corresponding holes in the fireplace face. Figure H-6. NOTE: Make sure the brackets are positioned as shown in Figure H-5.
5. Secure the bracket to the face through the top & bottom holes with (2) of the screws provided (A). Figure H-6.
6. Repeat for left mounting bracket.

*Secure brackets at top & bottom holes with screws provided.*



7. Position the tabs (lower end previously cut), on the shroud, 2 each side, into the slots in the fireplace face and align the oblong holes on the left & right inside flange of the side shroud pieces to the holes in the mounting brackets. Secure with the remaining (4) screws (C), 2 each side. Figure H-7.

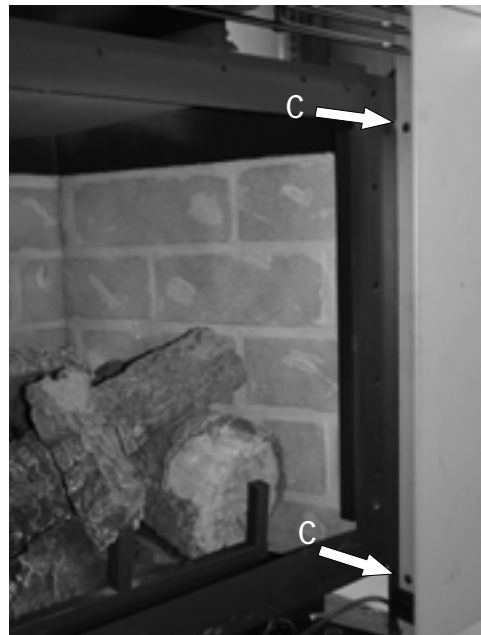

*Figure H-7*

**CONNECT THE ROCKER SWITCH WIRES TO THE VALVE**

Refer to Figure N-1 page #24 for wiring diagram, if necessary.

1. Slide the remaining connectors on the rocker switch wire to the top and bottom terminals marked 'TH' on the valve.

**COMPLETE THE INSTALLATION:**

1. Replace the glass assembly. Refer to Figure C-1, page #6, if necessary.



*Completed Shroud Installation*

## I. COMPLETE THE FAN INSTALLATION:

This insert comes complete with a fan, speed control and temperature limit switch assembly already installed. This fan is equipped with a three-prong (grounding) plug attached to the end of the 8 ft. fan electrical cord for protection against shock hazard and should be plugged directly into a properly grounded three-prong receptacle. Do not remove the grounding prong from the plug. Do not allow any excess fan cord to touch the firebox.

1. Attach the limit switch on the left side of the millivolt board under the firebox.
2. Plug fan cord into the nearest, properly grounded receptacle.

Note: The fan will not operate unless the speed control has been turned on. The fan will not turn on until sufficient heat is applied to the thermostatic control switch. The fan will then turn on and off automatically as the fireplace heat and cools. Adjust fan to desired speed while it is running.

**NOTE: THIS FAN SYSTEM, WHEN INSTALLED, MUST BE ELECTRICALLY CONNECTED AND GROUNDED IN ACCORDANCE WITH LOCAL BUILDING CODES, OR IN THE ABSENCE OF LOCAL BUILDING CODES, WITH THE NATIONAL ELECTRICAL CODE, ANSI/NFPA 70.**

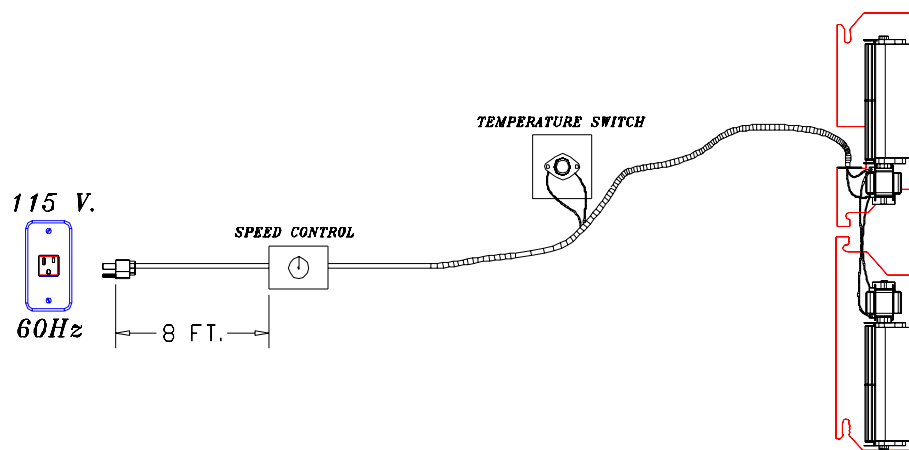

**CAUTION: WHEN INSTALLATION OF THE MILLIVOLT BOARD IS COMPLETE, CHECK TO ENSURE THAT THERE ARE NO WIRES, FLEX LINES, ETC., TOUCHING THE FAN TERMINALS.**

## J. COMPLETE THE INSTALLATION

1. THIS STEP SHOULD ONLY BE DONE BY A QUALIFIED INSTALLER OR SERVICE TECHNICIAN:

- A) Perform lighting and shutdown procedures as described on pages #19-20. This should be done prior to replacing the glass so that any necessary adjustments can be made and proper operation and log position is verified.

2. SEASONAL HEAT DUMP ADJUSTMENT:

This fireplace insert has been manufactured with a heat vent damper located at the top inside the firebox. This allows infinite control over the amount of heat emitted into the living area without affecting the flame height.

INSTALLER: Please install this fireplace insert with the heat vent damper in the closed position.

HOMEOWNER: This fireplace insert has been installed with the heat dump in the closed position and will operate at its peak efficiency. The heat dump may be opened as much as necessary to maintain desired heat level.

TO ADJUST:

**CAUTION: DO NOT ATTEMPT TO ADJUST THE HEAT DUMP OPENING IF THE FIREPLACE HAS BEEN IN OPERATION. ALLOW AMPLE TIME TO COOL OR USE THE APPROPRIATE PROTECTION TO AVOID SERIOUS BURNS AND/OR PROPERTY DAMAGE.**

- A. Remove the glass assembly & open or close the damper as desired.

HEAT OUTLET  
SHOWN IN  
CLOSED POSITION.

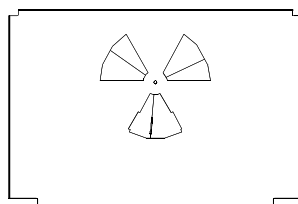
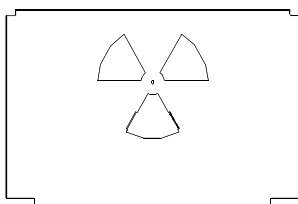

HEAT OUTLET SHOWN  
IN PARTIALLY OPENED  
POSITION.

3. REPLACE THE GLASS FRAME ASSEMBLY. Refer also to Figure J-1.

**WARNING: DO NOT OPERATE THIS FIREPLACE WITH THE GLASS ASSEMBLY REMOVED, CRACKED, OR BROKEN.** Replacement of the glass assembly should be done by a licensed or qualified service person.

- A. Align the 3 slots in the top of the glass assembly over the 3 tabs on the fireplace (at the top).  
B. Place the glass assembly so it is flush with the front of the fireplace front.  
C. While holding the glass assembly, pull the latches out and secure over the glass latch clips on the bottom of the glass frame locking it in place.

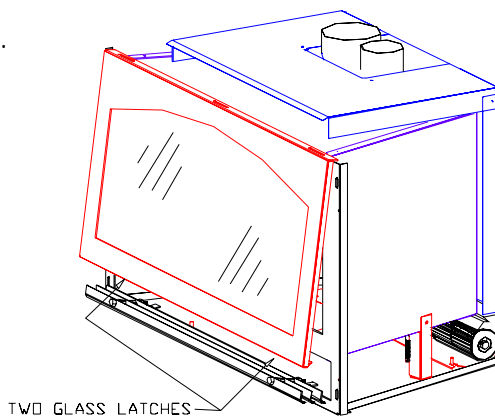

Figure J-1

4. INSTALL THE LOWER GRILL. Refer to Figure J-2.

- A. Remove the (2) 1/4" nuts from the lower grill.  
B. Place the bolts through the hinges in the lower grill opening.  
C. Attach the 1/4" nuts.  
D. Tighten both 1/4" nuts.

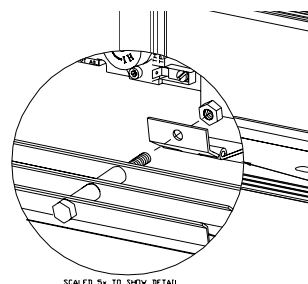

Figure J-2

## K. THERMOSTAT - WALL SWITCH - REMOTE INSTALLATION (optional).

**CAUTION: DO NOT connect high voltage (115 V) wire to the switch.**

If desired, a thermostat (wireless available), wall switch *or* remote control assembly may be used to turn the fireplace 'OFF' and 'ON'. Only one of these may be installed. Follow instructions included with each kit.

**IMPORTANT:**  
High voltage (115v) is not required to operate any of these systems.

**OPTIONAL:** Disconnect the ON/OFF rocker switch wires from the top & bottom terminals on the gas valve. Refer to Figure N-1, page #24.

**NOTE:** INSTALLATION OF A THERMOSTAT OR WALL SWITCH SHOULD ONLY BE DONE BY A QUALIFIED INSTALLER.

**REMOTE CONTROL USERS:**

Follow Instructions included with the remote control.

**IMPORTANT:** An insulated cover is included with the remote control and must be placed over the receiver to protect it from overheating.

**WALL SWITCH / THERMOSTAT USERS:**

Run low-voltage (thermostat) wire from the terminals on the gas valve to the desired location of the thermostat or wall switch.

Attach the appropriate connector to each wall switch / thermostat wire and connect to the top and bottom terminals marked 'TH' on the gas valve.

**Figure K-1  
Thermostat Wiring Diagram**

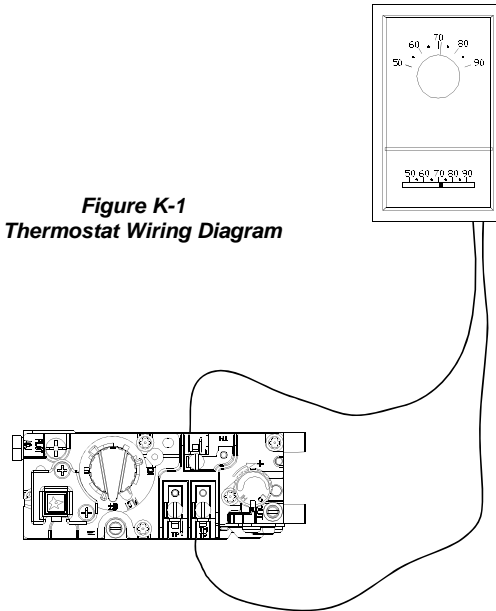

**IMPORTANT:** The on/off rocker switch on the shroud must be in the 'OFF' position for proper operation of any of these components.

If the rocker switch is 'ON', the fireplace burner will operate until it is turned 'OFF' by the rocker switch. A wall switch, thermostat, or remote control will not turn the fireplace 'OFF' when it has been turned 'ON' by the rocker switch.

**Note:** The fireplace must be turned 'ON' and 'OFF' by the same method. For example: If the fireplace is turned 'ON' by the remote, it must be turned 'OFF' by the remote.

**Remote Control Wiring Diagram**

**Figure K-2**

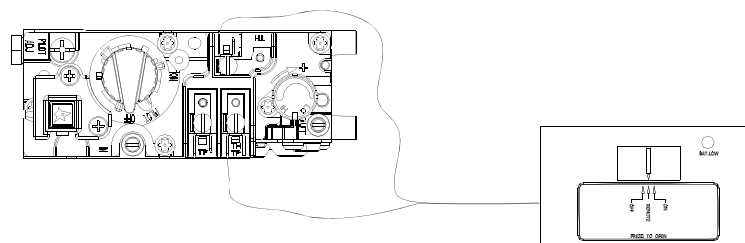

## L. LIGHTING & SHUTDOWN

**NOTE:** Prior to lighting, check all fittings for leakage. This is accomplished by applying soapy water on all connections made. If there is any leakage, bubbles will appear at the point of connection. If bubbles occur, tighten the fittings until the bubbles no longer appear.

**IMPORTANT: TEST ALL CONNECTIONS WHETHER FIELD OR FACTORY MADE.**

**NOTE:** The appliance and its individual shutoff valve must be disconnected from the gas supply piping system during any pressure testing of that system at test pressures in excess of ½ psi.

**NOTE:** The appliance must be isolated from the gas supply piping system by closing its individual manual shut off valve during any pressure testing of the gas line at test pressures equal to or less than 1/2 psig (3.5 kPa).

Pressure check taps for the manifold (outgoing) and inlet (incoming) pressures are located in front of the gas valve. The right pressure tap is the manifold pressure and the left pressure tap is the incoming pressure. Follow instructions on page #21 for check these pressures.

### FOR YOUR SAFETY - READ BEFORE LIGHTING

**WARNING:** If you do not follow these instructions exactly, a fire or explosion may result causing property damage, personal injury or loss of life.

- A. This appliance has a pilot which must be lighted by hand. When lighting the pilot, follow these instructions exactly.
- B. **BEFORE LIGHTING**, smell all around the appliance for gas. Be sure to smell next to the floor because some gas is heavier than air and will settle on the floor.
- C. Use only your hand to push in or turn the gas control knob. Never use tools. If the knob will not push in, or turn by hand, don't try to repair it, call a qualified service technician. Forced or attempted repair may result in a fire or explosion, and loss of warranty.
- D. Do not use this appliance if any part has been under water. Immediately call a qualified service technician to inspect the appliance and to replace any part of the control system which has been under water.

DO NOT STORE OR USE GASOLINE OR OTHER FLAMMABLE VAPORS AND LIQUIDS IN THE VICINITY OF THIS OR ANY OTHER APPLIANCE.

**DUE TO HIGH SURFACE TEMPERATURES, KEEP CHILDREN, CLOTHING AND FURNITURE AWAY.**

This appliance needs fresh air for safe operation and must be installed so there are provisions for adequate combustion and ventilation air.

#### WHAT TO DO IF YOU SMELL GAS:

- \*Do not touch electrical switches.
- \*Do not try to light any appliance.
- \*Do not use any phone in your building.
- \*Follow the gas supplier's instructions
- \*Immediately call your gas supplier from a neighbor's phone.
- \*If you cannot reach your gas supplier, call the fire department.

### LIGHTING INSTRUCTIONS

Refer to Figure L-1, page #20.

1. **STOP!** Read safety information above.
2. Open the lower grill by grasping the center of the top louver, then pull out and down to access the gas valve.
3. Set the thermostat to the lowest setting. (If installed.)
4. Turn off all electric power to the appliance. (Fan.)
5. Push in black control knob (A) slightly and turn clockwise  to "OFF".

**NOTE:** Knob cannot be turned from "PILOT" to "OFF" unless knob is pushed in slightly. Do not force.

6. Wait five (5) minutes to clear out any gas. If you then smell gas, **STOP!** Follow the safety information above. If you don't smell gas, go to the next step.
7. Find the pilot - follow metal tube from gas control. The pilot is behind the burner tube.
8. Turn the black control knob (A) on the gas valve counterclockwise  to "PILOT".

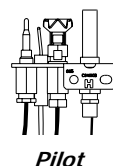

9. Push in the black control knob all the way and hold in. Press the igniter button (B). The pilot will generally light with two or three pushes on the igniter. Hold the knob in for about one (1) minute after the pilot is lit. Release knob and it will pop back out. Pilot should remain lit. If it goes out, repeat steps 5 through 9.

\*If knob does not pop out when released, stop and immediately call your service technician or gas supplier.  
\*If the pilot will not stay lit after several tries, turn the gas control knob to "OFF" and call your service technician or gas supplier.

10. Turn black control knob (A) counterclockwise to "ON".
11. Flip the ON/OFF switch (C) to the "ON" position. If using a thermostat, leave on/off switch 'OFF' and set the thermostat to desired setting.
12. Close the lower grill.
13. Turn on electric power to the fireplace.

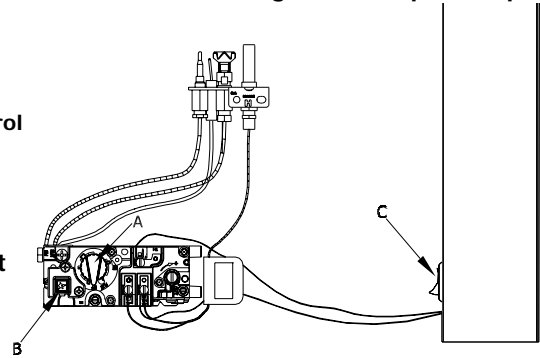

Figure L-1

**NOTE:** When this fireplace is initially lit, condensation will appear on the glass, this is normal in all gas fireplaces, and will disappear in one to three minutes.

14. If you wish to turn the burner off, flip the on/off switch to the 'OFF' position. If a wall switch has been installed, simply turn it off. If a thermostat has been installed, simply adjust temperature setting.

**NOTE:** The pilot will stay lit.

#### TO TURN GAS OFF TO THE FIREPLACE INSERT:

1. Open the lower grill by grasping the center of the top louver, then pull out and down to access the gas control valve.
2. Set the thermostat to the lowest setting. (If installed)
3. Turn off all electric power to the appliance if service is to be performed.
4. Push in control knob(A) slightly and turn clockwise to "OFF". Do not force.

KEEP BURNER & CONTROL COMPARTMENT CLEAN. REFER TO PAGE #22 FOR MAINTENANCE REQUIREMENTS.

#### INITIAL BURN PERIOD

AN ODOR WILL OCCUR DURING THE FIRST FEW HOURS OF BURNING. THIS IS DUE TO THE PAINT CURING AND SUBSTANCES USED IN THE MANUFACTURING PROCESS. IT IS RECOMMENDED TO LEAVE THE FAN (IF INSTALLED) OFF DURING THIS PERIOD AS IT WILL SPEED UP THE PAINT CURING PROCESS.

DUE TO THE MAKEUP OF THE LOGS & REFRACTORY, THEY WILL DISCOLOR DURING THE INITIAL BURN PERIOD. THIS MAY TAKE UP TO 4 HOURS OF BURN TIME. ONCE THE CURING PROCESS IS COMPLETE, THE TRUE COLOR WILL RETURN.

**IMPORTANT: DO NOT BURN THIS FIREPLACE WITHOUT THE GLASS ENCLOSURE PROPERLY IN PLACE.**

**\*\*MAKE SURE THE HOMEOWNER IS AWARE OF THIS\*\***

**NOTE:** Children and adults should be alerted to the hazards of high surface temperature and should stay away to avoid burns or clothing ignition. Young children should be carefully supervised when they are in the same room as the appliance.

Clothing or other flammable material should not be placed on or near the appliance.

**NOTE: THIS FIREPLACE MAY PRODUCE NOISES OF VARYING DEGREE AS IT HEATS AND COOLS TO DUE METAL EXPANSION AND CONTRACTION. THIS IS NORMAL AND DOES NOT AFFECT THE PERFORMANCE OR LONGEVITY OF THE FIREPLACE.**

## PRESSURE TESTING MANIFOLD & INLET PRESSURE

**IMPORTANT NOTICE:** A pressure check tap for both the manifold (outgoing) and inlet (incoming) pressure has been incorporated into the valve by Honeywell. The right pressure tap is the manifold pressure and the left pressure tap measures the incoming pressure. Follow the instructions below for proper pressure testing procedures.

### TO CHECK THE MANIFOLD PRESSURE:

1. Light pilot .
2. Loosen the manifold pressure tap [D] by turning the screw counter-clockwise.
3. Attach manometer to pressure tap using a 5/16" I.D. hose [F].
4. Turn control knob [A] to the 'ON' position.
5. Turn the burner 'ON' by depressing the rocker switch [C] and note the manometer reading.
6. Depress the rocker switch [C] to the 'OFF' position.
7. Disconnect manometer hose and tighten screw (clockwise). Screw should be snug, do not over tighten.
8. Attach manometer to manifold pressure to verify that it is completely sealed. Manometer should read no pressure when the rocker is turned 'ON'.

**NOTE:** If manifold pressure reading is within the normal range, an incoming pressure check is not necessary. A too high or too low pressure reading warrants an inlet (incoming) gas pressure check.

### TO CHECK THE INLET PRESSURE:

1. Loosen Inlet pressure tap screw [E] by turning screw counter-clockwise
2. Attach manometer using a 5/16" I.D. hose [F].
3. Light the pilot.
4. Turn the control knob [A] to the 'ON' position and note manometer reading. (Burner should not turn 'ON'.)
5. Depress the rocker switch [C] to the 'ON' position and check the pressure to ensure that it stays near the maximum inlet pressure.
6. Depress the rocker switch [C] to the 'OFF' position.
7. Turn the pilot to the 'OFF' position.
8. Disconnect hose and tighten screw (clockwise). Screw should be snug, do not over tighten.
9. Relight pilot and turn the control knob [A] to the 'ON' position. Attach manometer to the inlet pressure tap to verify that it is completely sealed. Manometer should read no pressure.

**NOTE:** If Inlet pressure reading is too high or too low, contact the gas company. Only a qualified gas service technician should adjust the incoming gas pressure.

**CAUTION:** A LOW PRESSURE READING CAN CAUSE DELAYED IGNITION.

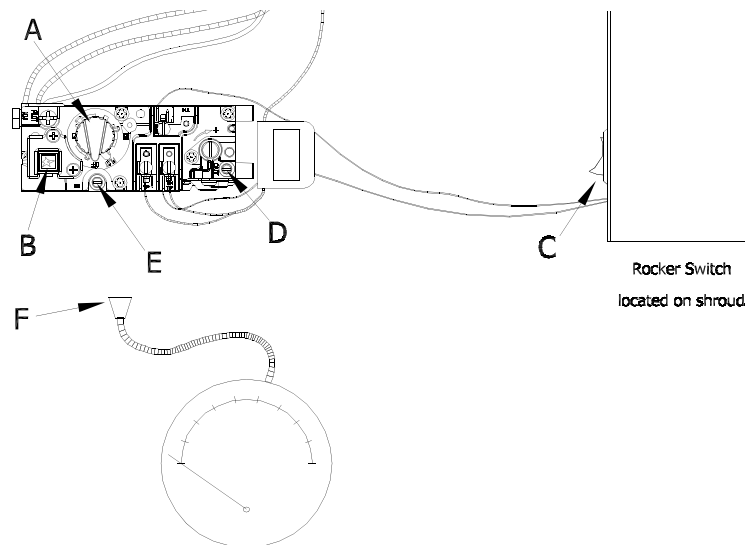

FIGURE L-2

## M. MAINTENANCE REQUIREMENTS

1. The appliance should be inspected at least once a year by a professional service person.

NOTE: INSTALLATION AND REPAIR SHOULD BE DONE ONLY BY A QUALIFIED SERVICE PERSON. THE APPLIANCE SHOULD BE INSPECTED BEFORE USE AND AT LEAST ANNUALLY BY A QUALIFIED SERVICE PERSON. MORE FREQUENT CLEANING MAY BE REQUIRED DUE TO EXCESSIVE LINT FROM CARPETING, BEDDING MATERIAL, ETC. IT IS IMPERATIVE THAT CONTROL COMPARTMENTS, BURNERS AND CIRCULATION AIR PASSAGEWAYS OF THE APPLIANCE BE KEPT CLEAN.

DO NOT OBSTRUCT THE FLOW OF COMBUSTION AND VENTILATION AIR.

2. The compartment below the firebox (behind the lower grill) must be cleaned at least once a year, more frequent cleaning may be required due to excessive lint from carpeting, bedding materials or other fibrous materials. It is imperative that the burner be cleaned once a year.

---

### FAN

The fan should be disconnected from electrical current, and cleaned (vacuumed) every six months. The bearings are sealed and require no oiling.

---

### VENT SYSTEM

Annual examination of the venting system by a qualified agency is required.

1. Remove the glass assembly.
2. For easier access, remove the logs.
3. Cover the millivolt board system.
4. Loosen and remove the (2) nuts securing the baffle at the back of the firebox.
5. Examine proper sealing of vent system.
6. Re-install the baffle and nuts. Tighten nuts only enough to secure baffle. Baffle must be allowed to 'float' as the fireplace heats and cools.
7. Re-install the logs and glass.

NOTE: If the vent-air intake system is disassembled for any reason, reinstall and seal in accordance to the instructions on pages #8 - #9 of this installation manual.

---

ANY SAFETY SCREEN OR GUARD REMOVED FOR SERVICING MUST BE REPLACED PRIOR TO OPERATING THE APPLIANCE.

### MILLIVOLT BOARD SYSTEM

1. Annual cleaning of the burner is required. The burner cover may be removed for easier access. Refer to Figure C-2, page #6.

Visually check for blocked port holes, especially near the pilot. Blocked port holes may cause delayed ignition.

2. Visually check the pilot light and burner when they are burning. The flames should be steady, not lifting or floating.



Burner Orifice

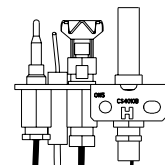

Honeywell Pilot

### GLASS CLEANING & REPLACEMENT

- Clean glass only when cool and only with non-abrasive cleansers.
- *Do not* operate this fireplace with the glass / frame assembly removed, cracked or broken.
- The glass, Part #700-01T *shall only be replaced as a complete unit*, as supplied by Hussong Mfg. Co., Inc.
- Replacement of the glass, Part #700-01T, must only be performed by a licensed or qualified service person. **DO NOT SUBSTITUTE MATERIALS.**
- *Do not* strike or slam glass door assembly.

---

CAUTION: KEEP THE APPLIANCE AREA CLEAR OF COMBUSTIBLE MATERIALS, SUCH AS GASOLINE AND OTHER FLAMMABLE VAPORS AND LIQUIDS.

CAUTION: LABEL ALL WIRES PRIOR TO DISCONNECTION WHEN SERVICING CONTROLS. WIRING ERRORS CAN CAUSE IMPROPER AND DANGEROUS OPERATION. VERIFY PROPER OPERATION AFTER SERVICING.

## N) TROUBLE SHOOTING GUIDE

NOTE: The millivolt board includes the following items: Regulator, generator, pilot, thermocouple, piezo, electrode, burner cover assembly, orifice and orifice holder. If any of these items are defective, contact your dealer for the appropriate repair / replacement procedures to follow.

WARNING: DO NOT ATTEMPT TO SERVICE THIS FIREPLACE IF YOU ARE NOT A QUALIFIED SERVICE PERSON.

1. If the fireplace fails to ignite, a qualified service person should check the fireplace installation.
2. It is imperative that the control compartment, burner and circulation air passageways of the fireplace be kept clean. This is necessary to provide adequate combustion and ventilation air.
3. All of the working parts of this fireplace can be removed at one time. Before removing millivolt board, check for loose wires.

<u>PROBLEM</u>	<u>CAUSE</u>	<u>SOLUTION</u>
1. No spark when piezo button is depressed.	Piezo wire connection on valve is loose or off.	Push wire back into place.
	Wire from piezo to electrode is loose at electrode.	Replace electrode assembly.
	Electrode moved out of position.	Realign electrode with 1/8" space between it and pilot.
2. Pilot won't light.	Gas shut 'OFF'.	Turn Gas 'ON'.
	Gas line not purged.	Hold control knob in long enough to purge line.
	Not holding control knob in long enough.	Hold in longer.
3. Pilot won't stay lit.	Not holding control knob in long enough.	Hold control knob in longer to heat generator.
	Thermocouple wire loose at valve connection.	Check connection on valve.
	Pilot hood misdirecting pilot flame from thermocouple.	Check pilot flame location. Flame must be burning on generator and thermocouple.
	Pilot shield not installed or not in proper position.	Install pilot shield and/or ensure proper position. See Figure F-1, page #11.

PROBLEM

CAUSE

SOLUTION

4. Burner won't light.

Pilot not lit.

Relight pilot.

Regulator valve not turned to 'ON'.

Turn valve to 'ON'.

Rocker switch not turned 'ON'.

Press the switch to the "ON" position.

Rocker switch wires not connected.

Check wiring diagram Figure N-1 and ensure that all wires are secure.

Generator wires loose at valve terminals.

Reposition wire and tighten screws. See Figure N-1 for wiring instructions.

Generator wire grounded out due to pinching of wires.

Nuts on millivolt board may need loosening to remove pinched wire.

Wall switch, remote control or thermostat not connected properly or turned to wrong setting. See Figures K-1 & K-2, page #18.

Connect properly or disconnect and on/off switch only.

5. Burner won't stay lit.

Generator wire loose a valve terminals.

Reposition wires and tighten screws. See Figure N-1 for wiring instructions.

Generator wire grounded out due to pinching of wires.

Nut on millivolt board may need loosening to remove pinched wire.

Generator is not producing enough millivolt to sustain burner operation.

Check millivolt reading, replace generator is necessary.

Refractory panels are not positioned against firebox back & sides.

Secure refractory panels with high-temp sealant.

*Wiring Diagram  
Figure N-1*

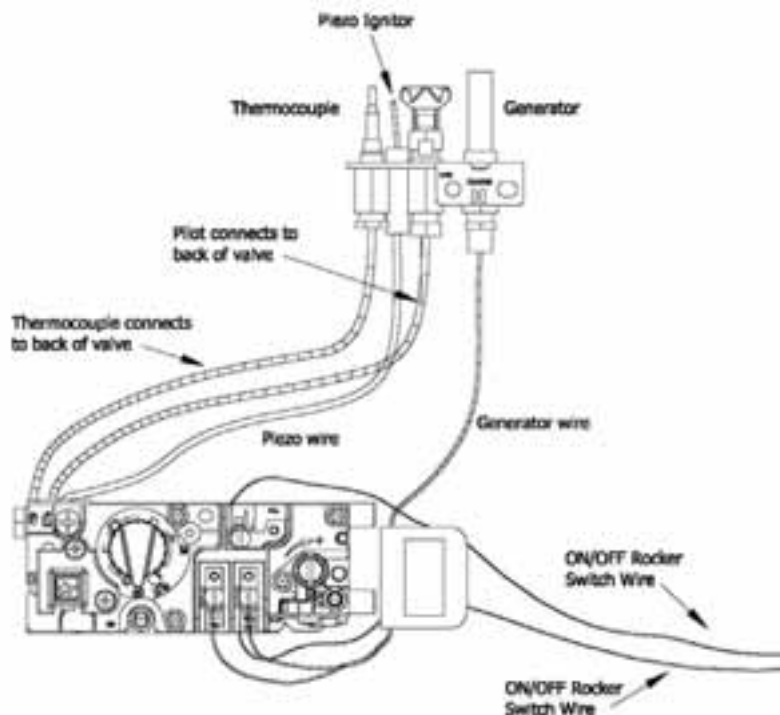



## GAS CONVERSION KIT FOR MODEL #911-XXL DV I INSERT EQUIPPED WITH THE HONEYWELL GAS VALVE & PILOT ASSEMBLY

THIS CONVERSION KIT SHALL BE INSTALLED BY A QUALIFIED SERVICE AGENCY IN ACCORDANCE WITH THE MANUFACTURER'S INSTRUCTIONS AND ALL APPLICABLE CODES AND REQUIREMENTS OF THE AUTHORITY HAVING JURISDICTION. IF THE INFORMATION IN THESE INSTRUCTIONS IS NOT FOLLOWED EXACTLY, A FIRE, EXPLOSION, OR PRODUCTION OF CARBON MONOXIDE MAY RESULT, CAUSING PROPERTY DAMAGE, PERSONAL INJURY OR LOSS OF LIFE. THE QUALIFIED SERVICE AGENCY IS RESPONSIBLE FOR THE PROPER INSTALLATION OF THIS KIT. THE INSTALLATION IS NOT PROPER AND COMPLETE UNTIL THE OPERATION OF THE CONVERTED APPLIANCE IS CHECKED AS SPECIFIED IN THE INSTRUCTIONS SUPPLIED WITH THE KIT. REFER TO THE APPLIANCE OWNER'S MANUAL OR PRODUCT DATA PLATE FOR PROPER INLET AND MANIFOLD PRESSURE ADJUSTMENTS AND ORIFICE SIZING.

- This kit includes:
- (1) Hi/Lo Conversion screw & regulator cap with instructions
  - (1) Instruction sheet for converting the pilot assembly
  - (1) Main Burner Orifice #30 Natural Gas or #47 LP gas
  - (1) 'Gas Conversion' label
  - (1) 'Gas Type' oval label

**CAUTION:** Before proceeding with the conversion, the gas supply must be shut off prior to disconnecting the electrical power.

### PREPARE THE FIREPLACE:

1. Turn the gas valve to 'OFF' by pushing the control knob on the gas valve 'in' slightly and turn clockwise to the 'OFF' position.
2. Remove the glass assembly. Refer to the fireplace installation manual for instructions if necessary.
3. Remove logs, rock wool embers, and bottom refractory panels from the burner cover assembly and set aside on a properly protected surface. Refer to the fireplace installation manual for instructions if necessary.
4. Loosen and remove the two nuts securing the burner cover assembly to the millivolt board. Refer to the fireplace installation manual for assistance if necessary.
5. Remove the burner cover to expose the burner orifice and pilot assembly.

### REPLACE THE BURNER ORIFICE, FIGURE 1:

1. Loosen and remove the orifice 'cap'.
2. Thread the orifice cap included with this kit onto the orifice assembly & tighten.

Figure 1



### CONVERT THE PILOT ASSEMBLY:

- A. Locate the pilot assembly. Figure 2.
- B. Follow the instruction sheet included with this kit to properly convert the pilot to the appropriate gas type you are converting to.

Figure 2

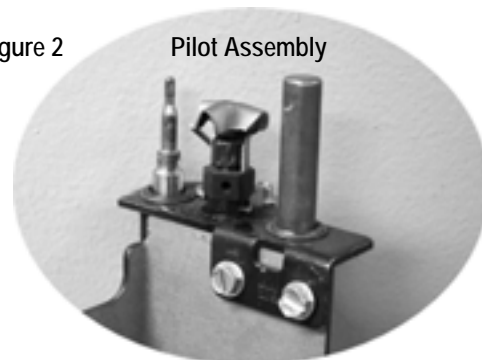

### CONVERT THE HI/LO REGULATOR ON THE GAS VALVE.

- A) Locate the gas valve behind the lower grill in the lower air passage.
- B) Convert the hi/lo regulator on the gas valve using the conversion screw and regulator cap included in this kit. Follow the instructions included with the conversion screw and regulator cap.

**ADJUST THE BURNER VENTURI SETTING:**

1. An adjustable air shutter is located at the end the burner tube and must be adjusted to the gas type you are converting to.

To adjust the venturi, loosen the screw (A) and adjust venturi opening to either the Natural Gas or LP Gas setting listed below. Re-tighten the screw. See Figure 3.

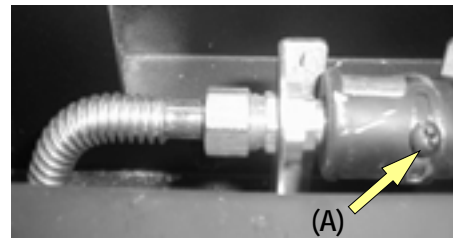

Figure 3

*Natural Gas - 3/16" open*  
*LP Gas - 1/2" open*

**COMPLETE THE CONVERSION:**

1. Replace the burner / cover assembly, ensuring the burner venturi is properly positioned over the burner orifice. Secure with the nuts previously removed. Refer to Figure C-2, page #6 for assistance if necessary.
2. Replace the bottom refractory panels, logs, and rock wool ember material. Refer to page #16 for assistance if necessary.
3. Light the pilot and turn the burner 'ON'. Refer to pages #19-#20 for assistance if necessary.
4. Check all connections for gas leaks, whether field or factory made.
5. Test incoming and manifold (outgoing) pressure. Refer to page #21 for pressure testing procedures.

Incoming pressure:	Natural Gas:	Minimum: 5.0" W.C. Maximum: 10.5" W.C.	LP Gas:	Minimum: 11" W.C. Maximum: 13" W.C.
Manifold Pressure:	Natural Gas:	3.5" W.C. - High 1.7" W.C. - Low	LP Gas:	10.0" W.C. - High 6.5" W.C. - Low
Input rating:	Natural Gas:	42,000 BTU's / hr.	LP Gas:	42,000 BTU's/hr.

6. Visually check the pilot. The pilot flame should envelope the top of the thermocouple and generator 3/8" to 1/2", and extend far enough onto the burner for proper ignition. Adjust the pilot flame if necessary.

- To adjust:
1. Remove the pilot adjustment cover screw from the gas control.
  2. Turn the inner pilot adjustment screw clockwise to decrease or counterclockwise to increase the pilot flame.
  3. Replace the pilot adjustment screw cover and firmly tighten after adjustment to ensure proper operation.

7. Turn the burner and pilot 'OFF'.
8. Affix proper 'gas type only' oval label over the existing label on the metal tag.
9. Replace the glass assembly. Refer to the fireplace installation manual if necessary.
10. Verify proper operation and ignition of the fireplace at both the 'high' and 'low' settings. Refer to the fireplace installation manual, if necessary.
11. Complete and affix the 'Gas conversion' label behind lower air passage, by the gas valve.

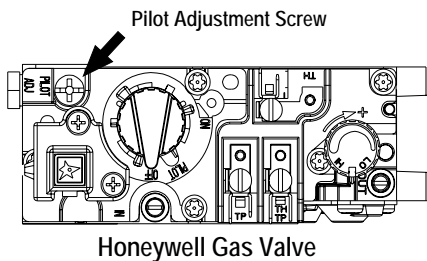

Honeywell Gas Valve

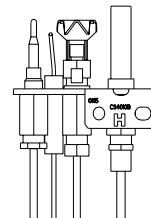

Honeywell Pilot Assembly

## REPLACEMENT PARTS

*Replacement parts are available through your local dealer. Information on optional components not listed below, is also available through your dealer.*

### MILLIVOLT BOARD AND PARTS

XXL-800	Millivolt Board - Natural Gas	700213B	18" Flexible Gas line - Black (gas line connection)
XXL-801	Millivolt Board - LP Gas	700224	3/8 Flexible Gas line (valve to burner orifice)
700203	Manual Shut off Valve	700230	Natural Gas Orifice - #30
700023	Off/On Rocker Switch	700247	LP Gas Orifice - #47
700057	Honeywell Valve - Natural Gas		
700057-1	Honeywell Valve - LP Gas	700075	Natural Gas Conversion Cap
700059	Thermocouple	700076	LP Gas Conversion Cap
700060	Pilot Tube with fitting (valve to pilot)		
700063	Pilot/Generator/Thermocouple - Nat. Gas	OCK-H30N	Natural Gas Conversion Kit
700063-1	Pilot/Generator/Thermocouple - LP	OCK-H47L	LP Gas Conversion Kit
700083	Piezo with ignitor	900035	Burner Tube
700092	Millivolt Generator	XXL035	Burner Plate
700203	Manual Shut-off Valve		

### FAN - REPLACEMENT ONLY

XXL-028	Fan Kit with temperature limit switch & speed control
600085	Speed Control
404-4	Limit Switch

### REMOTE CONTROLS / THERMOSTAT

796-2	Remote Control with Thermostat
797-1	Remote Control
700038	Wall-Mount Thermostat

### GLASS

700-01T	35" X 21" Glass with gasket
---------	-----------------------------

### AIR DUCT

XXLCL1	Co-linear Air Duct
--------	--------------------

### PAINT

300624	12 oz. aerosol touch-up paint - 'Satin Black'
--------	---

### LOG SET

XXL500	8 PC. Log Set
'S421' Log	
'S423' Log	
'S424' Log	
'BB' Log	
'BC' Log	
'X5' Log	
'BL' Log	
'AP1' Log	

900-REMB	Rock wool Embers
----------	------------------

### REFRACTORY

XXL-G900	Refractory Panels - 3 pc. (Back & Sides)
XXL-G901	Refractory Bottom - 2 pc.
XXL-G900S	Side Refractory Panel - 1 pc.

### GASKETS

911075	Gasket Set
--------	------------

*SPECIALTY DOORS & GRILL SETS: Contact your dealer for available styles & finishes.*

*SHROUDS & SHROUD TRIM: Contact your dealer for available styles & finishes.*

This appliance tested & certified by:  
OMNI-Test Laboratories, Inc.  
5465 SW Western Avenue  
Beaverton, Oregon 97075

U.S. Patents #5,931,154, #6,004,493, #6,029,655  
Model #XXL JACKSON - US INSTALLATIONS ONLY  
October 2006

[www.kozyheat.com](http://www.kozyheat.com)

**MANUFACTURED BY:**  
Hussong Manufacturing Company, Inc.  
204 Industrial Park Drive  
Lakefield, MN 56150

## **KOZY HEAT LIMITED 10 YEAR WARRANTY**

*Effective July 01, 2003*

This Limited 10 Year Warranty will not become effective until the warranty registration form has been completed and mailed to Hussong Manufacturing Co., Inc., P.O. Box 577, Lakefield, MN 56150. This registration form must be received within 30 days of installation. Failure to do so may result in delayed warranty coverage and submission of proof of purchase will be required.

Hussong Manufacturing Co., Inc. warrants to the original purchaser of this Kozy Heat Fireplace, that it is free of defects in materials and workmanship at the time of manufacture.

Subject to the following conditions & requirements, Hussong Manufacturing Co., Inc. extends the following limited warranty under normal use and service, with respect to the Kozy Heat line of gas burning fireplaces.

**YEAR 1:** Subject to the conditions & requirements listed below, within the first year from date of purchase, Hussong Manufacturing Co., Inc. shall, at its discretion, replace or repair any such defect in material or workmanship, at Hussong Manufacturing Co., Inc.'s expense, including reasonable labor costs to repair or replace the defective component, if a factory pre-authorization is given for the repair.

**YEARS 2 - 10:** Subject to the conditions & requirements listed below, beginning with the first day of the second year and continuing through the tenth year, Hussong Manufacturing Co., Inc., will at its discretion, provide repair or replacement parts at current list prices for any defect in material or workmanship of components, including optional components and accessories (if available). Hussong Manufacturing Co., Inc. shall not be responsible for any installation, labor, transportation or other indirect costs.

### **LIMITATION OF LIABILITY**

To make a claim under this warranty, the purchaser must first contact the dealer/installer from whom the fireplace was purchased.

This limited warranty will be void if the fireplace is not installed by a qualified installer and according to the installation instructions. Use of unauthorized components will make this warranty null and void.

This limited warranty also is void if the fireplace is not operated, at all times, according to the operating instructions furnished.

This warranty is limited to defects in material and workmanship. It does not apply to any product that has been subject to negligence, misapplication, improper installation. Remote control warranties are covered by Ambient Technologies, Inc., and are excluded from this Limited Warranty.

No person is authorized to extend the time of this warranty or to accept on Hussong Manufacturing Co., Inc.'s behalf any additional obligation of liability connected with the unit.

It is expressly agreed and understood that this warranty is Hussong Manufacturing Co., Inc.'s sole obligation and purchaser's exclusive remedy for defective fireplace equipment. Hussong Manufacturing Co., Inc. shall not be liable for any consequential, incidental or contingent damages whatsoever. The foregoing warranty is exclusive and in lieu of all other expressed warranties. Hussong Manufacturing Co., Inc. shall not be held to implied warranties, including but not limited to the implied warranties or merchantability and fitness for a particular purpose. This warranty replaces all previous warranty policies.

Some states do not allow the exclusion or limitation of incidental or consequential damages or limitations on how long an implied warranty lasts, so the above limitations or exclusions may not apply to you. This warranty gives you specific legal rights and you may also have other rights which vary from state to state.

Hussong Manufacturing Co., Inc. reserves the right to make changes at any time, without notice, in design, material, specifications and prices. Hussong Manufacturing Co., Inc. reserves the right to discontinue models and products.

#### **WARRANTY CONDITIONS & REQUIREMENTS:**

1. You are the original purchaser. This warranty is not transferable.
2. Installation of the fireplace is performed by a qualified installer.
3. Installation and operation must comply with installation and operation instructions.
4. Paint and glass gaskets are covered for 30 days from date of purchase.
5. Components broken, (including glass panels), during shipping, careless handling of components, or defects resulting from improper installation, misuse of the fireplace and components are not covered under this warranty.
6. This warranty does not cover any part of the fireplace or any components which have been exposed to or submerged under water.
7. Hussong Manufacturing Co., Inc. must be notified by the dealer the fireplace was purchased from or a qualified installer or service technician of the defect.
8. Annual service of the fireplace as required in the installation manual, is performed by a qualified installer/service technician. (Copies of such service records may be required to claim a warranty.)
9. All previous warranty/service has been performed by a qualified installer or service technician. (Copies of such service records may be required to claim a warranty.)



## LIFETIME WARRANTY

**THIS LIFETIME WARRANTY COVERAGE WILL BE EXTENDED AS DESCRIBED BELOW PROVIDED ALL WARRANTY CONDITIONS AND REQUIREMENTS ARE MET AS OUTLINED IN THE 10 YEAR LIMITED WARRANTY POLICY.**

### LIFETIME WARRANTY COVERAGE

LIFETIME WARRANTY IS EXTENDED AS FOLLOWS: Hussong Manufacturing warranties to the original purchaser that the firebox, heat exchanger, fiber logs, burner tube and glass of this Kozy Heat fireplace will not be defective in material or workmanship under normal use and service for as long as you own this product. If any of these components fail due to defects in material or workmanship under normal use and service, Hussong Manufacturing Co., Inc. will, at its sole discretion, repair or replace the defective component. This LIFETIME WARRANTY does not cover any installation, labor, transportation or other indirect costs arising from defective components.

### LIMITATION OF LIABILITY

This Lifetime warranty will be void if the fireplace is not installed by a qualified installer and according to the installation instructions. Use of unauthorized components will make this warranty null and void. This lifetime warranty also is void if the fireplace is not operated, at all times, according to the operating instructions furnished. This warranty is limited to defects in material and workmanship of components specified. It does not apply to any product that has been subject to negligence, misapplication, improper installation.

No person is authorized to extend the time of this Lifetime warranty or to accept on Hussong Manufacturing Co., Inc.'s behalf any additional obligation of liability connected with the unit.

Hussong Manufacturing Co., Inc. may fully discharge all obligations with respect to this Lifetime warranty by refunding the wholesale price of the defective component(s).

It is expressly agreed and understood that this Lifetime warranty is Hussong Manufacturing Co., Inc.'s sole obligation and original purchaser's exclusive remedy for defective fireplace equipment. Hussong Manufacturing Co., Inc. shall not be liable for any consequential, incidental or contingent damages whatsoever other than those incurred by Hussong Manufacturing Co., Inc. to repair or replace the defective component. The foregoing warranty is exclusive and in lieu of all other expressed warranties. Hussong Manufacturing Co., Inc. shall not be held to implied warranties, including but not limited to the implied warranties of merchantability and fitness for a particular purpose. This lifetime warranty replaces all previous lifetime warranty policies.

Hussong Manufacturing Co., Inc. reserves the right to make changes at any time, without notice, in design, material, specifications and prices. Hussong Manufacturing Co., Inc. reserves the right to discontinue models and products.

JUNE 1998

DISCARD BOTTOM LINE

**TO ACTIVATE THIS LIFETIME WARRANTY COVERAGE, THIS REGISTRATION CARD MUST BE COMPLETED AND MAILED WITH YOUR COMPLETED 10 YEAR LIMITED WARRANTY FORM WITHIN 30 DAYS OF INSTALLATION.**

**PURCHASER'S NAME:** \_\_\_\_\_

**INSTALLATION DATE:** \_\_\_\_\_

**ADDRESS:** \_\_\_\_\_  
\_\_\_\_\_

**MODEL#:** \_\_\_\_\_ **SERIAL #:** \_\_\_\_\_

**TELEPHONE #** \_\_\_\_\_

**INSTALLER NAME:** \_\_\_\_\_

**ADDRESS:** \_\_\_\_\_  
\_\_\_\_\_

**TELEPHONE #** \_\_\_\_\_